

ARA Single Panel Arrays

ARA Array Assemblies for CRB, CRN, CRM, CRC, CRZ, CRL, CRH and CRG E-Mitters®

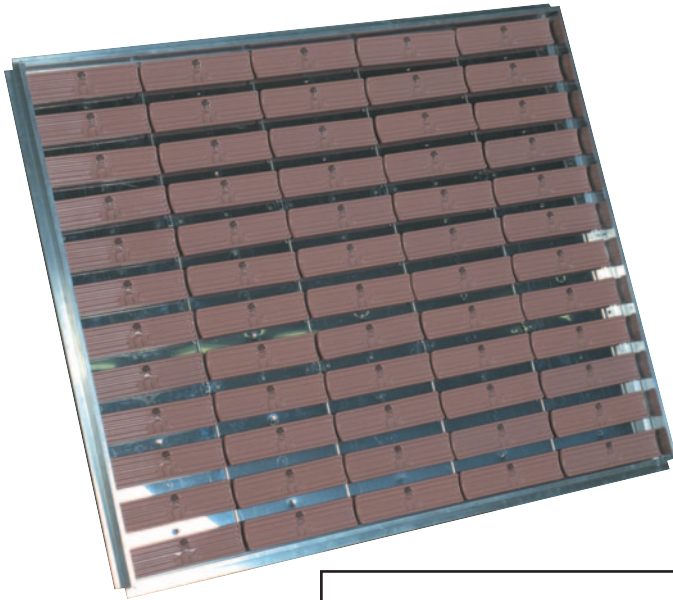

Design Features

- * Custom Engineered/Manufactured
- * Lightweight extruded aluminum outer housing
- * Each heater's power leads are connected to an individual ceramic terminal block
- * NCC or Nickel wire with heat resistant insulation is used for wiring between terminal blocks (see pages 7-21 through 7-23)
- * Zones with different radiant heat levels can be achieved by using different wattage heaters (each zone would have a heater with built-in thermocouple for temperature control)
- * Shipped fully assembled
- * Optional factory wiring and power control panels
- * Optional ceramic fiber insulation in wiring space
- * Optional entrances in rear cover or sides to customer specs

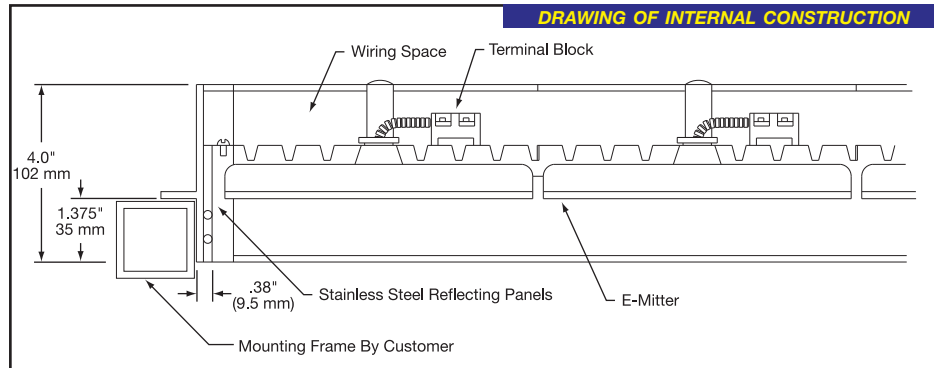

Steps to Design a Custom ARA E-Mitter Array for your application

- 1.) Select a panel array size for the Style E-Mitter:
CRB and CRN E-Mitter panel sizes can be found on page 7-29.
CRM E-Mitter panel size can be found on page 7-30.
CRC and CRZ E-Mitter panel sizes can be found on page 7-31.
CRL E-Mitter panel sizes can be found on page 7-32.
CRH and CRG E-Mitter panel sizes can be found on page 7-33.
CRD E-Mitter panel sizes can be found on page 7-35.
- 2.) Determine any special heat zoning.
- 3.) Specify any E-Mitters that will have thermocouples.

*There is
No Substitute
for Our Experience*

**SATISFACTION
GUARANTEED!**

Ordering Information

Refer to the worksheet on page 7-36



DANGER: Hazard of Fire. These heaters are not for use in atmospheres where flammable vapors, gases or liquids are present as defined in the National Electrical Code. Where solvents, water, etc. are being evaporated from the process it is necessary to provide substantial quantities of ventilating air to carry away all resulting vapors.

Do not mount heater closer than 6 inches to any structural material that does not have at least a 200°C continuous temperature rating.

WARNING: Hazard of Electric Shock. Installation must be grounded to earth to avoid shock hazard. Disconnect power to installation before servicing or installing heater.