

Tempco Replacement Mini-Coil Heaters (Round Cable) for OEM Hot Runner Systems

Tempco's Mini-Coil Band Heaters are designed and manufactured under the tightest tolerances so that they may be used in hot runner/runnerless injection mold tooling with complete confidence on maintaining the manufacturer's original balanced heating when using a minimum of thermocouples and temperature control zones.

- $\pm 2\%$ Resistance Tolerance
- 5" and 7" Staggered Cold Lead Length
- 72" Insulated Lead Wire Length
White/Black for 250W and White/Red for 125W

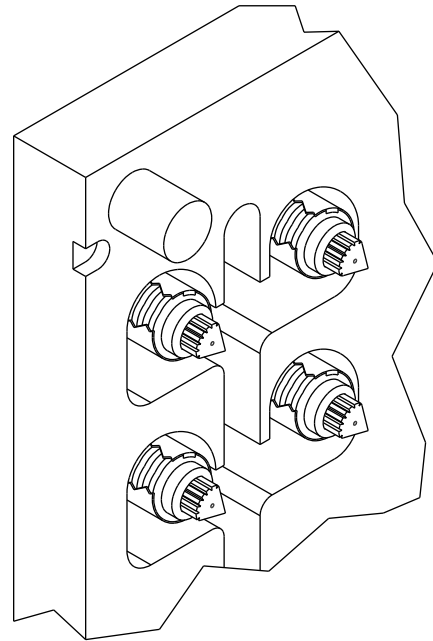

Cam Operated Clamping

Clamp Screw Clamping

Clamp Screw

Clamping

Screw operated clamping for the traditional style.

Cam Operated Clamping

Cam operated axial clamping allows tool room personnel to replace the heating element or the thermocouple of the gate bushing without having to remove the bushing from the mold. This can even be done in emergencies while the mold is still in the press, saving hours of downtime. The hex head cam is accessed from the front, parallel to the bushing's shaft.

Specifications

Mechanical

- Coil Heater Diameter:** 0.055", ± 0.002 "
- Thermocouple:** Type J, 0.055" dia., ± 0.002 "
- Inner Diameter:** ± 0.002 "
- Width/Length:** ± 0.020 "
- Axial Clamp Hex:** Tempered 416 series SS
Hex size: 1/8"
Rotation: 150 degrees
- Clamp Screw:** (2) 6-32 \times 1/2", SS,
Hex size 7/64"
- Heater Leads:** 18 ga. silver coated copper, Teflon[®]
insulation, 200°C/392°F
Staggered 5" and 7"
- Thermocouple Leads:** Fiberglass insulation, 1000°F

Electrical

- Resistance Tolerance:** $\pm 2\%$
- Wattage Tolerance:** $\pm 2\%$
- Voltage:** Standard voltages are 120 and 240VAC;
other voltages can be designed.
Consult Tempco with your requirements.