

Current Indicators

Current Indicators

Wire-Mounted Current Indicators

Tempco's wire-mounted electrical current indicators provide an effective method of monitoring electrical current. The indicator is attached directly to a current-carrying wire. When the current exceeds the turn-on point, the LED will illuminate to indicate the presence of current.

Red LED Indicator

Part Number: CTT00001

Green LED Indicator

Part Number: CTT00002

Panel Mounting Bracket

Part Number: CTT00003

Wire Passes	Turn-On Point (Amps AC)		Max. Wire Dia. (in.)
	Red LED	Green LED	
1	2	2.5	.29
2	1	1.25	.14
3	.66	.83	.13
N	$2 \div N$	$2.5 \div 2$	-

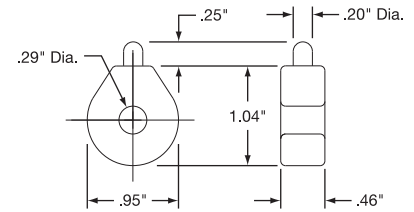
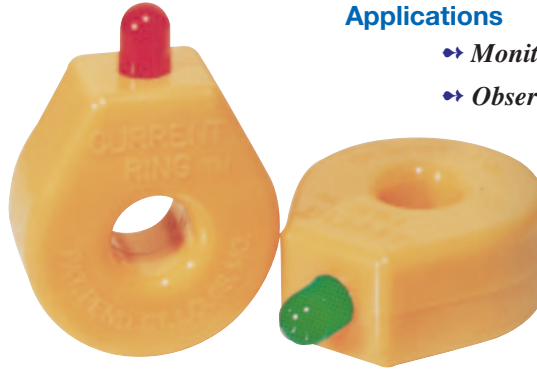

Design Features

- * Self Powered
- * Easy to Install
- * Supplied with Plastic Tie
- * Indicates Current from 2 to 100 Amps AC (1 Wire Pass)

Applications

- ➔ Monitor Heater Element Status
- ➔ Observe Remote Loads

Remote Current Indicators

The Tempco remote current sensing transformer is installed around the current-carrying wire and is connected directly to the LED panel indicator. When the current exceeds the turn-on point of the sensing transformer, the LED illuminates to indicate the presence of current. Two sizes of remote current sensing transformers are available for use with either of two types of LED indicators listed below at right.



Specifications

Max. Wire Dia.: .29 inches
 Indicating Range: 2 to 100 Amps AC
 Max. Transient Current: 150A for 5 sec.
 Working Class: 600 Volts, 50-60 Hz
 Lead Wire Length: 12"
 Max. Operating Temperature: 140°F/60°C
 Part Number: CTT00004

Specifications

Max. Wire Dia.: .55 inches
 Indicating Range: 2.5 to 100 Amps AC
 Max. Transient Current: 150A for 5 sec.
 Working Class: 600 Volts, 50-60 Hz
 Lead Wire Length: 24"
 Max. Operating Temperature: 140°F/60°C
 Part Number: CTT00005

Typical Applications

- ➔ Indicate Open Heater Elements
- ➔ Observe Remote Loads
- ➔ Indicate Phase Loss
- ➔ Monitor Motor Operation

Surface Mounting Bracket

For use on model CTT00005 only

Dimensions: 1.37" x 1.25"
 Mounting Dims.: (2) #6 screws .87" apart
 Part Number: CTT00006

All Items Available from Stock

Panel LED Indicators for Remote Current Transformers

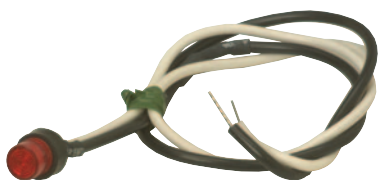

Press-In Panel LED Indicator with 12" leads

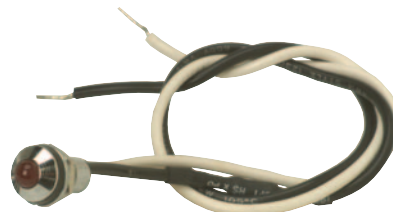

Splash-Proof Panel LED Indicator with 12" leads

Press-In LED Panel Indicator

LED Type: T-1-3/4", Red Bipolar
 Mounting Hole: .250"
 Part Number: CTL00001

Splash-Proof LED Indicator

Supplied with rubber sealing washer LED Type: T-1-1/4", Red Bipolar
 Mounting Hole: .312"
 Part Number: CTL00002

Current Sensing Relay for Heater Monitoring

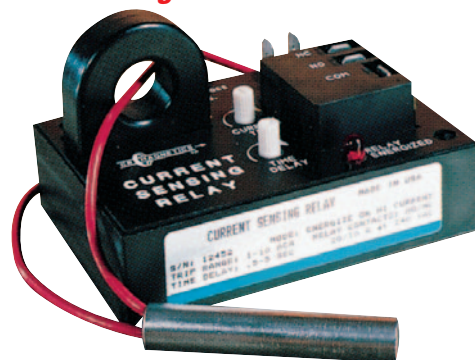
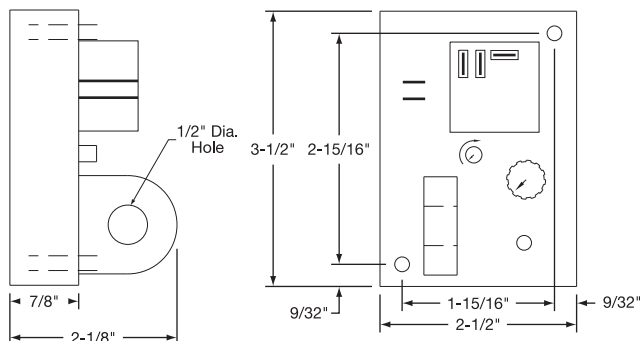

Specifications

Mounting: 2-3/16" dia. clearance holes on 1-15/16" by 2-15/16" centers

Environmental:

Operating Temperature: -30°C to +60°C

Storage Temperature: -55°C to +125°C

Power-On Delay: 100 ms max.

Hysteresis: 5% max.

Input Power Supply: 120 or 240Vac, 24 Vdc (Tolerance ±10%)

Input Terminals: 2-1/4" Male Quick Connect

Operating Class: 600 V

Sensed Current:

Max. Continuous: 200% Full Scale

Frequency: 60-400 Hz

Output Relay:

Arrangement: 1 Form C (SPDT)

Terminals: 3-1/4" Male Quick Connect

Contact Rating: NO-120/240 Vac: 20A, NC-120/240 Vac: 10A

Common Configurations

(with Calibrated Dial & Standard Relay)

Part Number	Trip Status	Supply Voltage	Trip Range (Amps)	Delay (sec)
CTR00201	LC	120	1 to 10	2 to 25
CTR00202	LC-Latch	120	1 to 10	2 to 25
CTR00203	LC	240	3 to 30	2 to 25
CTR00204	LC-Latch	240	3 to 30	2 to 25
CTR00205	LC	240	10 to 100	2 to 25
CTR00206	LC-Latch	240	10 to 100	2 to 25

The TEMPCO series of **Current Sensing Relays** provides an effective and highly stable method for monitoring electrical current. The current-carrying wire is routed through the opening extending from the top of the case. When current reaches the level set by the trip point adjustment, the electromechanical relay is energized. An adjustable timer is provided to delay activation of the relay. A precision voltage reference circuit ensures a highly repeatable trip point. Design of the power-on delay circuitry allows the supply power to be repeatedly cycled on and off without affecting the stability of the current sensing operation.

Design Features

- * Variable Trip Point and Time Delay
- * Monitors Currents from 10 mA to 100 AC Amps
- * Output Relay Rated Up to 20 Amps
- * LED Relay Status Indicator
- * Dead Band Prevents Relay Chatter
- * Calibrated Dial
- * Electrical Isolation Between Circuits

Typical Applications

- Monitor Electrical Heater Elements
- Sense Motor Over/Under Loads
- Detect Lamp Burnout
- Indicate Phase Loss

Ordering Code: **CTR** - 1 2 3 4 5 6

Relay Trip Status BOX 1

- 1** = Relay Energized on High Current (above trip point)
- 2** = Relay Energized on Low Current (below trip point)
- 3** = Latch on High Current
- 4** = Latch on Low Current

NOTE: For 3 and 4 relay remains latched until supply power is removed

Supply Voltage BOX 2

- 1** = 120 Vac
- 2** = 240 Vac
- 3** = 24 Vdc

Trip Ranges BOX 3

- 3** = 1.0 to 10 AC Amps
- 4** = 3.0 to 30 AC Amps
- 5** = 6.0 to 60 AC Amps
- 6** = 10 to 100 AC Amps

Time-On Delay BOX 4

- A** = .5 to 6 Sec.
- B** = 2 to 25 Sec.
- C** = .1 to 1 Sec.
- X** = None

Trip Point Dial BOX 5

- CD** = Calibrated Dial
- FP** = Fixed Setpoint (specify required value)

Output Options BOX 6

- R** = Standard Relay
- N** = Isolated NPN Transistor
- T** = Isolated Triac

Ordering Information

Current Relays are offered with the options listed in the worksheet above. Create an ordering code by filling in the boxes with the appropriate number and/or letter designation for your requirements and a part number will be assigned, or choose a common configuration. **Standard lead time is stock to 3 weeks.**

⚠ WARNING: Cancer and Reproductive Harm - www.P65Warnings.ca.gov.